

Longitudinal cutting automatic slitter LCM225EEN - working width 2250 mm -

Designed for the longitudinal cutting of conveyor belts.







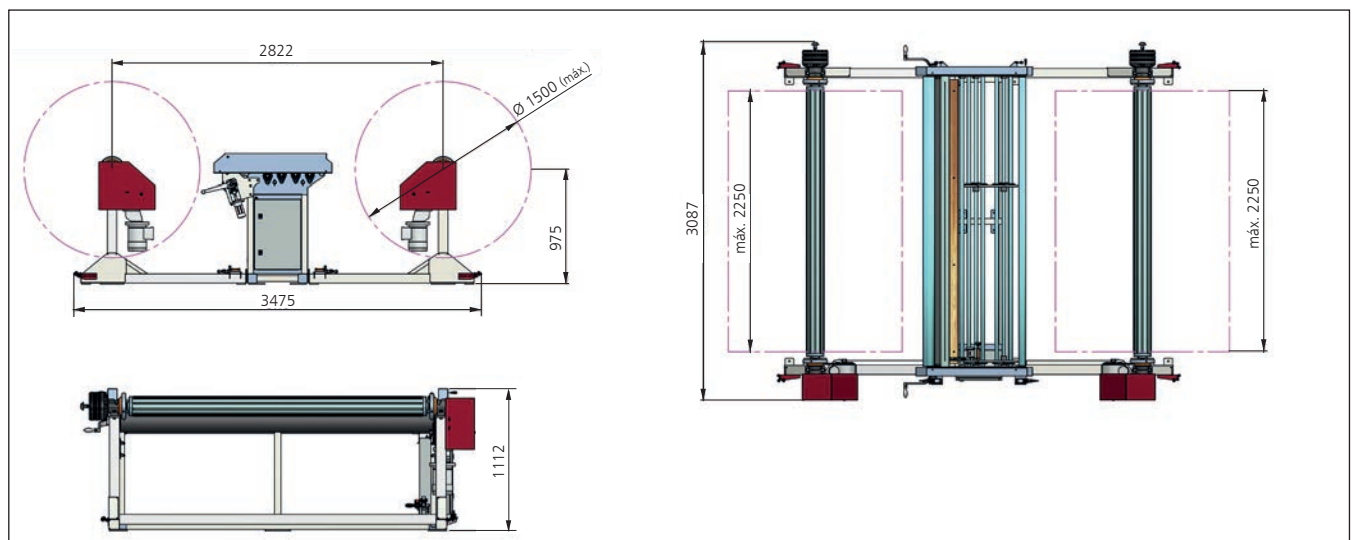

- Maximum belt width: **2,250 mm**. Minimum cut width: 100 mm.
- Reduced size, easy to place.
- It allows rolls with a **maximum diameter of 1,500 mm** and a weight of:
 - Roll **up to 1,000 mm wide**, the maximum permissible weight is **1,500 kg**.
 - Roll **up to 1,500 mm wide**, the maximum permissible weight is **2,000 kg**.
 - Roll **up to 2,250 mm wide**, the maximum permissible weight is **2,500 kg**.
- Permits cutting of belts up to 9 mm thick.
- The initial cutting speed varies between 0 and 8 m/min, slowly increasing in proportion to the diameter of the roll. However the cutting speed may be adjusted as necessary, using the potentiometer to control the frequency converter which, in turn, regulates the motor.
- Winder and unwinder/rewinder with automatic system to activate winding and rewinding.

SPECIFICATIONS:

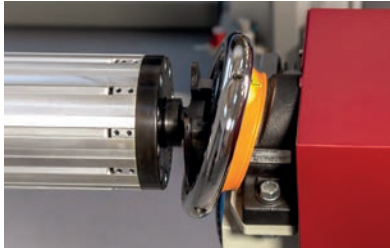
Width mm	Length mm	Height mm	Weight (without accessories) Kg	Total Power cv	Voltage V	Speed m/min
3087	3475	1112	760	two gear-motors 1,5 cv at 1500 rpm	220 single-phase	0 - 8

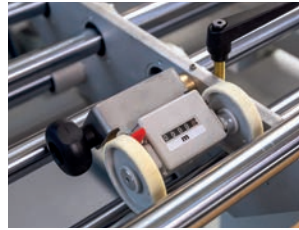

Longitudinal cutting automatic slitter LCM225EEN

FEATURES:	BENEFITS:
<p>Expandable pneumatic axles.</p>   <p>Attachment system using extendable axles with automatic safety lock, triangular in shape.</p>	<p>Guarantee that the roll is firmly gripped, both in the winder and the unwinder-rewinder.</p> <p>Facilitate mounting on the machine.</p>
<p>Central cutting zone, with revolving idler system.</p> <p>Adjustable guides.</p>  	<p>Facilitate threading of the belt and ensure belt tightness.</p> <p>Prevent sideways movement of the belt and ensure a clean, straight cut at a constant width.</p>
 <p>Mechanical metre counter.</p>	<p>Length of cut can be checked at all times.</p>
 <p>4 blade holders with 20 trapezoidal spare blades.</p>	<p>Permits four cuts to be carried out. Simple, clean and effective cut.</p> <p>No traction required in the cutting zone, unlike circular slitters.</p> <p>Easy to position.</p> 
 <p>Double strand steel chain as traction system.</p>	<p>Very robust traction system.</p>

Longitudinal cutting automatic slitter LCM225EEN

FEATURES:	BENEFITS:
<p>ELECTRICAL PANEL in the central part of the machine, with control panel for all machine operations.</p>   <p>Mounting function towards the winder and rewinder function</p>  <p>Automatic system for winding and rewinding the belt.</p>  <p>Braking system controlled by the "Winding Brake" & "Rewinding Brake" dials on the control panel.</p>	<p>The location ensures an overview of the entire machine.</p> <p>The MOUNTING/UNMOUNTING switch on the control panel facilitates the mounting of the belt on the slitter.</p> <p>The WINDING/ REWIND switch on the control panel operates automatically the winding and rewinding of the belt, allowing the operator to work in a fast and agile manner.</p> <p>Allows uniform braking and it is easy to regulate on both the winder and rewinder. It prevents the roll of belt from unwinding in one way or the other. The control dials at the central panel facilitates the job of the operator.</p>
<p>EMERGENCY STOPS:</p>  <p>Emergency button on the control panel</p>  <p>Perimetral emergency stop cables around the machine that are activated by foot at the winder and rewinder zones.</p> 	<p>Safety measures for the machine operators.</p>

Accessories for LCM225EEN

ACCESSORIES AND FEATURES:

LCU KAM-225

Handle which can be added to the slitter, enabling manual advance of the belt at an even, continuous rhythm.



The control panel is prepared with the CIL-UP/CIL-DOWN switch in case the optional accessory LCU-KAM-225 is to be added to the slitter.



BENEFITS:

Facilitates the operators' work in advancing the belt.

Permits short belts to be cut without the need to use the winder and with just one operator.

Guide to facilitate crosswise cutting of the belt.



The control panel is equipped with this switch by default such that when the LCU-KAM-225 mechanism is acquired later on, it could be easily added to the slitter without having to modify the electrical installation.